

EAGLE IP

HD ETHERNET
UNDERWATER CAMERA

OTAQ

OTAQ Eagle IP Cameras deliver an incredible blend of high performance specifications and features in a cost effective package.

Class leading low light colour optics are the key to the superb HD image that our camera produces. The camera is available as either a fixed focus (F) or 18x optical zoom (Z) model with all models having up to 1080P resolution and light sensitivity as low as 0.001 lux.

Eagle IP cameras are available in a wide range of depth ratings from 300m to 6000m and materials including acetal, anodised aluminium and stainless steel.

IP Integration Products

Eagle IP cameras have been designed to work with our Q-LINK and Q-HUB network infrastructure products that can provide a complete underwater IP camera network or get full HD video over your existing STP copper and fibre optic umbilicals.

Suitable applications

- Commercial ROVs and AUVs of all sizes
- Monitoring platforms
- Landers
- Marine renewables inspection
- Touchdown monitoring
- Oceanographic research

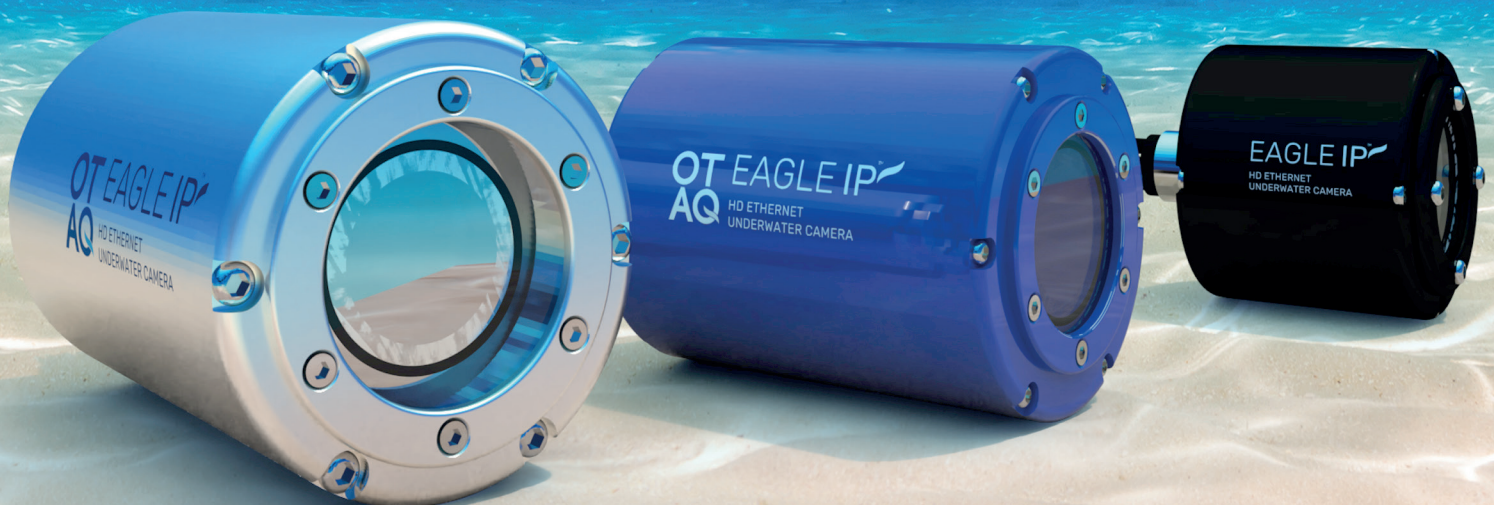

Model	IPZ/300	IPZ/1000	IPZ/4000	IPZ/6000	IPF/300	IPZ/1000	IPZ/4000	IPZ/6000
Lens	4.7-84.6mm Motorized 18 x Zoom Lens				8mm Fixed (digital zoom through GUI)			
Material	Acetal	Anodised Aluminium	Anodised Aluminium	Titanium	Acetal	Anodised Aluminium	Anodised Aluminium	Titanium
Depth rating	300m	1000m	4000m	6000m	300m	1000m	4000m	6000m
Power	18-30vDC@250mA				18-30vDC@200mA			
Transmission	H.264, ONVIF, RTSP				H.264, ONVIF, RTSP			
Data	10/100 BaseT Ethernet				10/100 BaseT Ethernet			
Min light level	0.01 lux				0.001 lux			
Latency	400ms				400ms			
Max res	1920x1080 (1080P @25fps) variable through GUI				1920x1080 (1080P @25fps) variable through GUI			
Field of View	60°~4.5° in air, 45°~3.3° in water				98° in air, 73° in water			
Connector	MCBH6M wet mate				MCBH6M wet mate			
Part no	OS-120100	OS-120105	OS-120110	OS-120115	OS-120200	OS-120205	OS-120210	OS-120220

Also available in Stainless Steel

EAGLE IPZ/1000

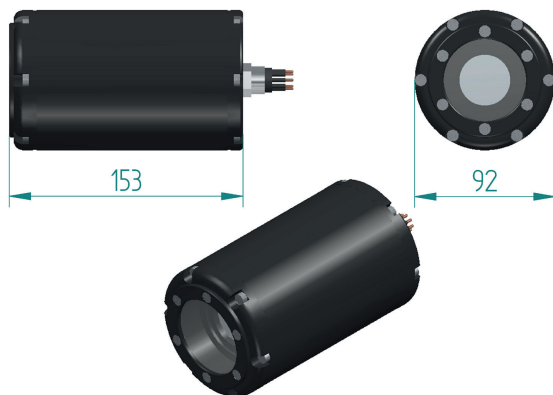

EAGLE IPF/1000

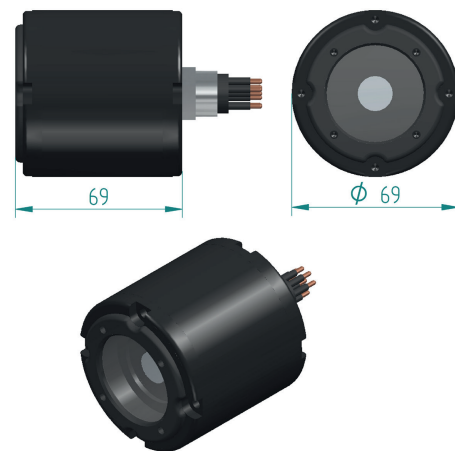

A Subsidiary of OTAQ plc
Specifications subject to change without notice. Images are representative.

OTAQ Offshore Ltd
Crombie Lodge
Aberdeen Innovation Park
Campus Two
Aberdeen, AB22 8GU, UK

+44 (0)1224 673301
info@otaq.com

otaq.com